

Operating manual (Translation of the original version)

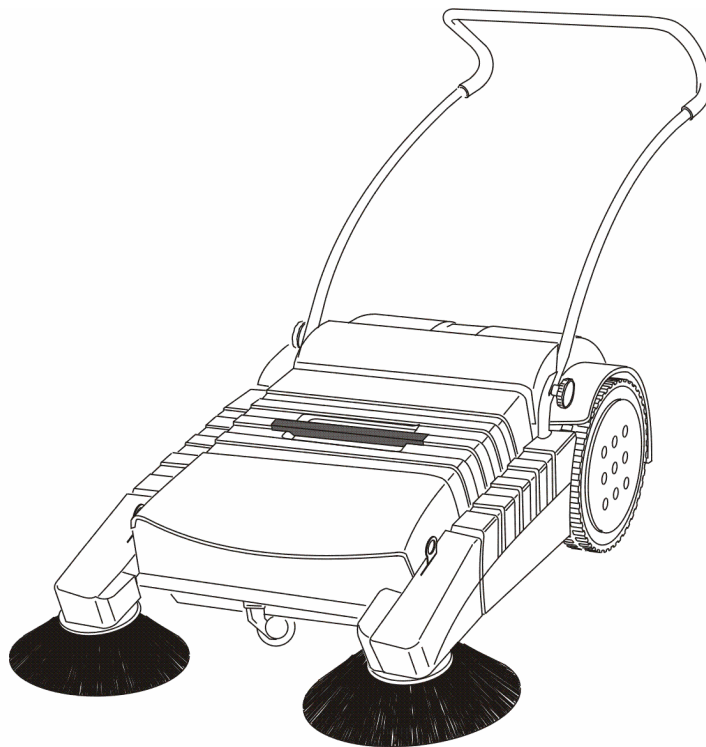

Matrix 900

Stolzenberg GmbH & Co. KG
Reinigungsmaschinen - Maschinenbau
Hamburger Str. 15 - 17
D-49124 Georgsmarienhütte

Telefon +49 (0 54 01) 83 53-0
Telefax +49 (0 54 01) 83 53-11

E-Mail: info@stolzenberg.de
Internet: www.stolzenberg.de

Table of Content

1	Introduction.....	3
1.1	Usage conformant with intended purpose	3
2	Safety information.....	4
3	Sweeper description	5
3.1	Sweeper description	5
3.2	Initial start-up	6
4	Operation.....	7
4.1	Sweeping	7
4.2	Height adjustment of the side brushes	7
4.3	After sweeping	7
4.4	Emptying the dustbin	8
5	Maintenance.....	9
5.1	Safety Information.....	9
5.2	Cleaning.....	9
5.3	Side brush replacement.....	10
5.3.1	Removing the side brushes.....	10
5.3.2	Mounting the side brushes	10
5.4	Brush roller replacement.....	11
5.4.1	Removing the brush rollers.....	11
5.4.2	Installing the brush rollers.....	11
5.5	Readjusting the brush rollers	12
5.5.1	Setting the brush rollers.....	12
5.5.2	To lower the brush rollers.....	12
5.5.3	To raise the brush rollers.....	13
5.6	Changing the chain	13
5.7	Maintenance Chart.....	13
5.7.1	Daily maintenance	13
5.7.2	After each 50 operating hours also	14
5.7.3	After each 100 operating hours also	14
5.8	Disturbances – Disturbance Display and Remedy	14
5.9	Technical Data	15
5.10	Disposal	15

5.11	Accessories and spare parts	15
5.12	Service	15
5.13	Transport.....	15

1 Introduction

This operating manual contains instructions for using the hand-operated sweeper.

Our products are subject to continuous improvement. Therefore, design changes that were made after this manual went to print could not be incorporated. If you have any questions, please contact our Service department.

The operating manual must be read and applied by all persons who operate the sweeper.

Apart from the operating manual and the regulations for accident prevention applicable in the country of use and the location of use, the common, recognised rules for safe and technically correct working must also be followed.

1.1 Usage conformant with intended purpose

The appliance is intended exclusively for sweeping on solid surfaces (for example.: parking areas, walkways, shop floors). The area to be swept should not be wet.

The sweeper may only be used by reliable and instructed personnel. prevent children, juveniles and other unauthorised persons from using the machine (e.g. by pulling out the key after use).

Any other use, or any use over and above that, will be considered to be non-conformant with intended purpose. The manufacturer rejects any and all liability for damage resulting from such use. The risk is that of the user alone.

Usage conformant with intended purpose also includes compliance with the operating manual and the inspection and maintenance specifications. Drive the sweeper only along expressly marked routes and spaces.

2 Safety information

1. The machine should only be used in a flawless state, as well as in keeping with its intended purpose, in a safety-conscious and risk-conscious manner and in compliance with these operating instructions.
2. In addition to the operating manual, please heed general legal and other binding regulations for accident prevention and environmental protection.
3. Sweeping and picking up of flammable, toxic or explosive substances, along with flammable gases or diluted acids and solvents, burning or smouldering objects is prohibited!
4. The appliance is not suitable for picking up fluids, cables, cords, wires or the like.
5. The machine should only be used with the dust box fitted to prevent injuries caused by parts being slung out.
6. Transporting loads with the sweeper is not allowed.
7. Faults should be eliminated immediately, particularly those that could impair safety.
8. Do not make any changes, modifications or additions to the sweeper without the approval of the manufacturer.
9. Replacement parts must meet manufacturer specifications. This is always ensured by using original replacement parts.
10. Ensure that operating media, auxiliary media and replacement parts are disposed of in a safe and environmentally-friendly manner, particularly batteries!
11. Suitable non-slip footwear should be worn to avoid accidents.
12. If you have any questions, please contact our Service department.
13. Persons (including children) who are not able to use this machine safely due to their physical, sensory or mental capabilities or their inexperience or lack of knowledge may not use this machine without the supervision or instruction by a responsible person! Children should be supervised to ensure that they do not play with the appliance.
14. Caution: loose clothing can be caught and drawn in on rotating parts.

3 Sweeper description

3.1 Sweeper description

The sweeper has been equipped with two side brushes and two counter-rotating brush rollers.

The sweeping mechanism features two side brushes which convey the refuse to the two brush rollers that are mounted parallel to the direction of motion.

The brushes throw the refuse overhead in the rear dirt collector.

A chain drives the brush rollers, and a V-belt drives the side brushes through the forward motion of the running wheel.

The modular design of the Matrix series allows for retrofitting the Matrix with a brush roller drive and with a dust extraction unit.

The Matrix MTX-900 TRS sweeper is driven by manual power only, in other words, by pushing the driving hoop.

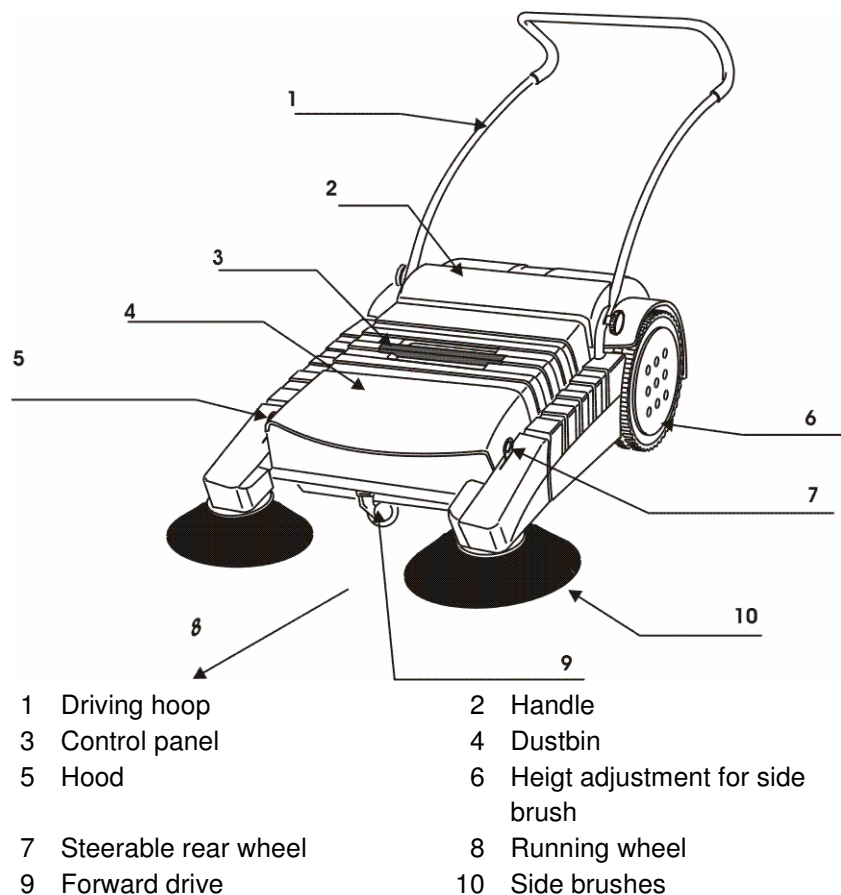

3.2 Initial start-up

Unpacking and assembly

Open the packaging and carefully lift the machine off the pallet.

CAUTION



Caution! Danger of injury!

Reach under the frame of the machinery to lift it. There is a risk of injury if you attempt to lift the machinery at the hood, the side brush retainer, or the dustbin.

- Place the driving hoop on the retainers.
- Slide the square necked bolts through the bore holes in the driving hoop and the retainer.

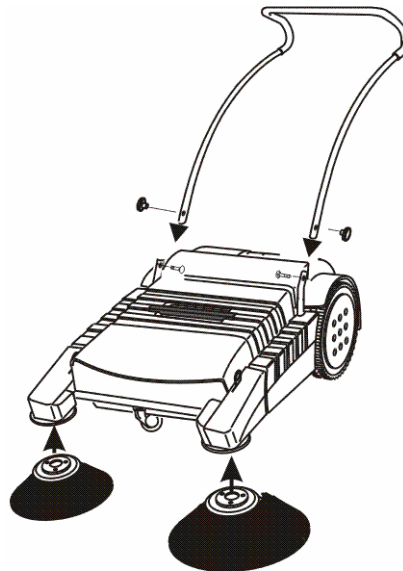

- Use the star knobs to secure the square necked bolts.
- Set the side brush arms to the top position.
- Position the side brushes under the side brush retainers.
- Turn the side brushes until the bore holes of the side brush disc line up with the pins of the side brush retainer.
- Push the side brushes into the side brush retainers until you feel the side brushes lock into place.

The sweeper is ready for operation.

4 Operation

4.1 Sweeping

Lower the side brushes until the tips touch the ground.

Push the sweeper across the area to be swept at a normal pace.

Since the sweeping performance depends on the speed of the brush rollers, you should neither walk too slowly nor too quickly. (e.g. run)

The side brushes remove dirt from corners and edges.

The sweeping mechanism will only work if the sweeper is pushed forward as it has been fitted with a free-wheel coupling to avoid whirling up dust unnecessarily.

4.2 Height adjustment of the side brushes

The side brush arms are located on the front side of the sweeper.

The height adjustment fixtures for the side brushes are located on the side brush arms.

- You can lower or raise both or just one side brush as needed.

To lower a side brush:

- Push the lever of the side brush adjustment fixture to the front.

To raise a side brush:

- Pull the lever to the rear.

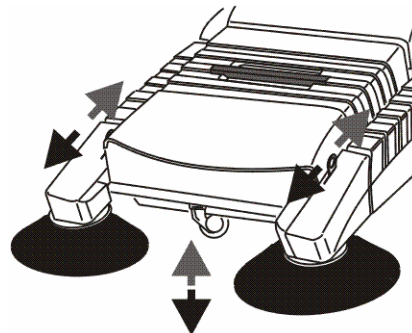

4.3 After sweeping

- Empty the dustbin in a suitable container.

Make sure the container is appropriate for this type of refuse.

- Insert the dustbin back into the sweeper.
- Set the side brushes to their top position.

Unless the side brushes are set to their top position, the bristles of the side brushes will be put under permanent load in their off-position and consequently will wear prematurely when used.

4.4 Emptying the dustbin

In order to ensure proper sweeping performance, the dustbin has to be emptied at regular intervals.

A handle is located on the top of the dustbin.

- Hold on to the handle and lift the dustbin out of the sweeper's frame.
- Empty the dustbin in a suitable container.
- Insert the dustbin back into the sweeper.

Do not park the sweeper with a full dustbin. Always empty the dustbin once you've finished sweeping.



5 Maintenance

5.1 Safety Information

Only complete the type of maintenance work described in the following chapter. All other maintenance and upkeep work may only be carried out by the manufacturer or by companies and persons authorised by the manufacturer, who are familiar with the relevant safety specifications, because portable devices in industrial use are subject to the safety test according to VDE 0701.

Closely follow the steps listed in the maintenance instructions. The improper completion of maintenance tasks may result in malfunctions when using the sweeper and may possibly render the warranty granted null and void.

Maintenance work/ troubleshooting at the electric motor must not be done while the electric motor is running.

Use only flawless and appropriate tools to complete maintenance work.

Note the requirements for spare parts.

If covers and/or safety devices were removed during maintenance work/repairs, they will have to be reattached prior to starting the sweeper.

For carrying out any work on the sweeper, it must be secured from rolling away by accident.

5.2 Cleaning

The suction sweeper may only be cleaned when it is dry.

Do not use any high-pressure cleaners.

5.3 Side brush replacement

5.3.1 Removing the side brushes

- Park the sweeper on level ground that has been designated (assigned) for this purpose.
- Make sure the sweeper has been secured from rolling away by accident.
- Lift the side brushes.
- Reach under the side brushes.
- With your fingers squeeze together the snap-in fixtures in the centre of the side brush retainer.
- With a downward motion, pull off the side brushes.
- Replace the side brushes.

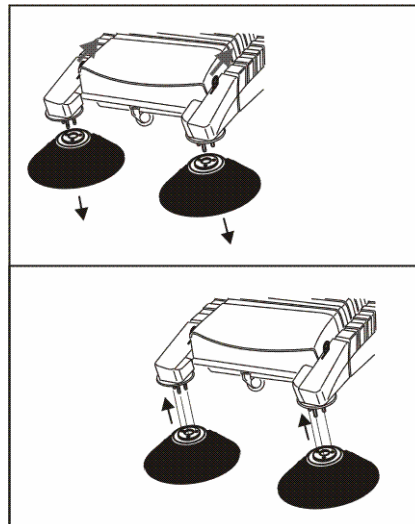

5.3.2 Mounting the side brushes

- Position the side brushes under the side brush retainers.
- Turn the side brushes until the bore holes of the side brush disk line up with the pins of the side brush retainer.
- Push the side brushes into the side brush retainers until you feel the side brushes lock into place.

5.4 Brush roller replacement

5.4.1 Removing the brush rollers

Every brush roller consists of two split shells with brushes.

- Screws join the split shells.
- Park the sweeper on level ground that has been designated (assigned) for this purpose.
- Make sure the sweeper has been secured from rolling away by accident.
- Remove the dustbin.
- Turn the sweeper on its back.
- Make sure the running wheels can move freely.
- Turn the top running wheel until you can see the screwed connections on the brush roller.
- Undo the screwed connections.
- Lift the split shells with the brush rollers off the shaft.
- If needed clean the running gear box and the shaft.

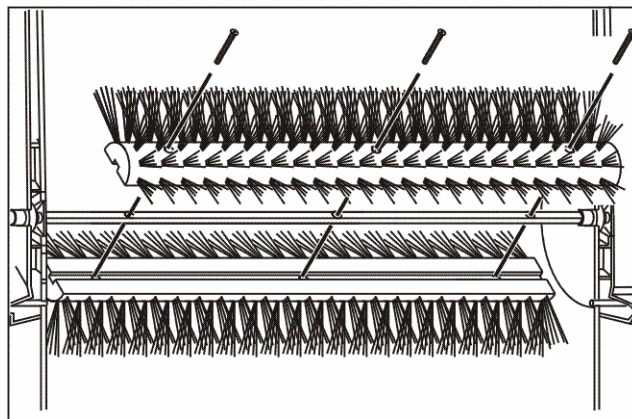

5.4.2 Installing the brush rollers

- The split shells have square recesses, which retain the brush roller shaft.
- Position the first split shell under the square shaft of the brush roller.
- Make sure the shaft fits flush into the recess of the split shell.
- Position the second split shell on top of the square shaft of the brush roller.
- To tighten use three screws for each set of brushes. Tighten until you can no longer see a gap between the split shells.

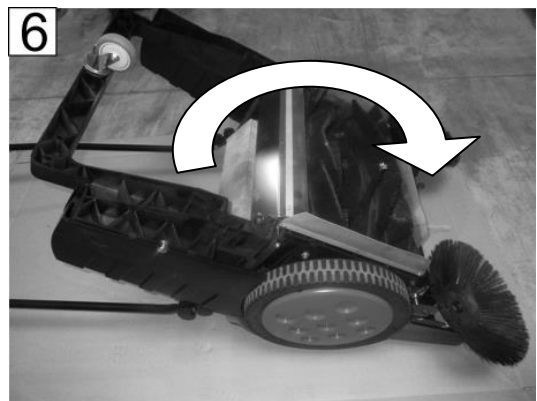
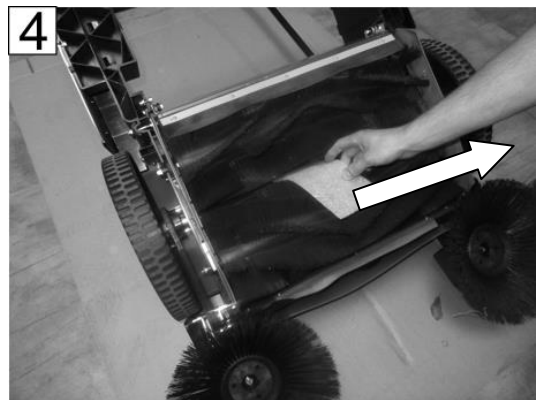
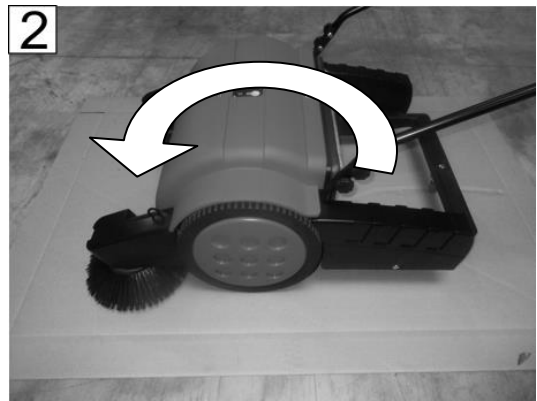

5.5 Readjusting the brush rollers

The height of the brush rollers can be adjusted to obtain the best possible cleaning results of the area to be swept and to effectively exploit the efficiency of the brush rollers.

The brush rollers need to be lowered once the sweeping performance starts to wane due to wear and tear of the brush rollers, or if the area to be swept is not level (bumpy).

If pushing the sweeper seems to become harder and you can hear the brush rollers scratching the ground, you will have to raise the brush rollers to ensure you use the sweeper ergonomically and to prevent the brush rollers from wearing prematurely.

On principle, the brush rollers should be set to ensure that they touch the ground at slight pressure.

5.5.1 Setting the brush rollers

- Park the sweeper on level ground that has been designated (assigned) for this purpose.
- Make sure the sweeper has been secured from rolling away by accident.
- Open the hood.

The rear trim panel of the frame reveals the height adjustment bracket to adjust the height of the brushes.

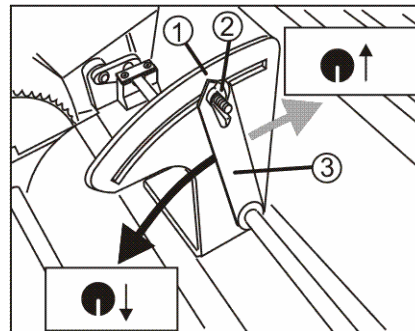

5.5.2 To lower the brush rollers

- Undo wing nut -2- on the height adjustment bracket -1-.
- Push down the rocker arm -3- in the direction of motion.
- The brush rollers are lowered.
- Tighten wing nut -2- on the height adjustment bracket -1-.
- Test the sweeper.
- Readjust if necessary

5.5.3 To raise the brush rollers

- Undo wing nut -2- on the height adjustment bracket -1-.
- Push down the rocker arm -3- in the direction of the dustbin.

The brush rollers are raised.

- Tighten wing nut -2- on the height adjustment bracket -1-.
- Test the sweeper.

Readjust if necessary

5.6 Changing the chain

De-tentioning or tentioning of the chain is proceeded by turning/ moving the DC-motor or the sprocket-support.

Position the machine on a appropriate surface.

- Make sure the machine is blocked against possible movement
- Open the cover.

Loosen the screws of the DC-motor or the sprocket-support to move the support by rotating it around the front/ first screw.

- By lowering the DC-motor or the sprocket-support, the chain is de-tentioned e.g. for changing the chain.
- Moving up the DC-motor or the sprocket-support tentiones the chain.
- Tighten the screws before operating the machine.

The tention of the chain is supported by the automatic chain-tentioner.

5.7 Maintenance Chart

5.7.1 Daily maintenance

- Charge battery.
- Check if machine is damaged or impaired in any way.
- Empty dust container.
- Search brush roller tunnel for jammed particles and seized up dirt that may narrow the brush tunnel and obstruct free roller brush movement.

5.7.2 After each 50 operating hours also

- Check if sweeping rollers are worn or cluttered. Replace if required.
- Check sweeping contour, readjust if required.
- Check if side brush adjustment is worn, if required readjust or replace.

5.7.3 After each 100 operating hours also

- Check cable isolation, replace cables if required.
- Search suction for obstacles, clean.
- Check if roller drive chain is elongated or loosened.
- Check all bearings for wear.
- Check if seals are damaged or dislocated.

5.8 Disturbances – Disturbance Display and Remedy

Disturbance	Possible Cause	Remedy
Sweeping result unsatisfactory:	Side brush(es) or main sweeping rollers not lowered	Lower
	Side brush(es) or main sweeping rollers worn	Adjust
	Trajectory clogged by dirt	Check if roller trim panel is impaired by jammed debris. Correctly fitted?
	Sweeping roller(s) do not operate	if required switch off side brushes
	Brush rollers are jammed by dirt, cords, strings or the like	Dismount brush rollers and clean them Check side brushes and remove obstacles
	Drive wheels obstructed	Jack up the Sweeping & Suction Machine check wheels and free running

5.9 Technical Data

Dimension and Weight	
Length	1091 mm
Width	760 mm
Height	416 mm
Weight	29 kg
Sweeping Width	
Main sweeping roller	500 mm
With one side brush	700 mm
With two side brushes	900 mm
Dust Container Volume	50 liter

5.10 Disposal

Dispose of faulty parts, especially electrical components, batteries and plastic parts according to the locally applicable waste disposal specifications.

Used batteries must be disposed of according to Directive 2006/66/EC.

5.11 Accessories and spare parts

Accessories and spare parts must conform to the requirements of the manufacturer. This is ensured by using genuine replacement parts.

5.12 Service

Stolzenberg GmbH & Co. KG
Hamburger Straße 15-17
D-49124 Georgsmarienhütte
Telefon: 0049 / (0)5401 83 53-0
Fax: 0049 / (0)5401 83 53-11
www.Stolzenberg.de

5.13 Transport

Transport the machine only in the switched-off condition, sufficiently well fastened.