

---

# Operating manual (Translation of the original version)

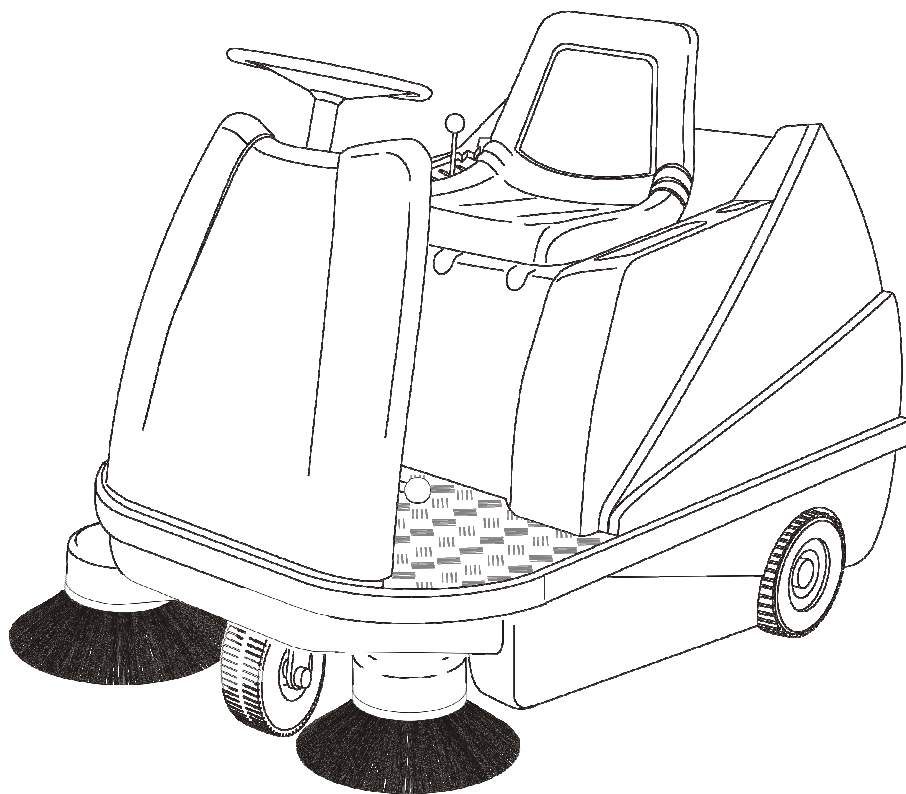

**TTE 1100**

2020-06-16

---

---

---

---

## Table of contents

<b>1</b>	<b>Introduction.....</b>	<b>4</b>
1.1	Usage conformant with intended purpose .....	4
<b>2</b>	<b>Safety information.....</b>	<b>5</b>
<b>3</b>	<b>Device Description .....</b>	<b>7</b>
3.1	Initial Startup .....	8
<b>4</b>	<b>Operation.....</b>	<b>10</b>
4.1	Driving .....	10
4.1.1	Forward motion:.....	11
4.1.2	Reverse motion: .....	11
4.2	Sweeping .....	12
4.2.1	Sweeping Roller Drive .....	12
4.2.2	Operatting the Sweeping Rollers.....	12
4.3	Operating the Side Brushes.....	13
4.4	Information provided by LED indicators on the battery condition display:.....	13
4.5	Operating the Suction .....	13
4.6	Adjustment of Driver`s Seat .....	14
4.7	Turning Off the Sweeping & Suction Machine .....	14
4.8	Operating the Filter Cleaning Device .....	14
4.9	Emptying the Dust Container .....	15
4.9.1	Removing the Dust Container .....	15
4.9.2	Reinserting the Dust Container .....	16
<b>5</b>	<b>Maintenance.....</b>	<b>17</b>
5.1	Safety Information.....	17
5.2	Cleaning.....	17
5.3	Charging the Batteries .....	18
5.4	Battery.....	19
5.5	Brake.....	19
5.5.1	Adjusting the Brake .....	19
5.6	Brake Check .....	20
5.6.1	Correct Operating of Brake.....	20
5.7	Steering.....	21
5.8	Replacement of Filter .....	21

## Table of contents

---

5.8.1	Removal.....	21
5.8.2	Reinsertion .....	22
5.9	Sweeping Rollers Replacement.....	22
5.9.1	Dismounting the Sweeping Rollers .....	22
5.9.2	Installing the Sweeping Rollers .....	23
5.10	Setting the Sweeping Rollers.....	24
5.10.1	Sweeping Contour Adjustment .....	24
5.10.2	Adjusting the Sweeping Contour .....	25
5.10.3	Further Possible Adjustment: .....	25
5.11	Replacing the Side Brush .....	26
5.11.1	Dismounting the Side Brush.....	26
5.11.2	Mounting the Side Brush .....	26
5.12	Adjustment of the Side Brush .....	27
5.13	Wheels .....	28
5.14	Fuses .....	28
5.15	Maintenance Chart.....	28
5.15.1	Daily maintenance .....	28
5.15.2	After each 50 operating hours also .....	28
5.15.3	After each 100 operating hours also .....	29
5.15.4	After each 200 operating hours also .....	29
5.16	Disturbances, Disturbance Display, Remedy .....	30
5.17	Technical Data .....	31
5.18	Product Marking.....	32
5.19	Disposal .....	32
5.20	Accessories and spare parts .....	33
5.21	Service .....	33
5.22	Transport.....	33
5.23	Wiring Diagram.....	34
<b>6</b>	<b>EC Declaration of conformity (Translation of the original version).....</b>	<b>35</b>



# 1 Introduction

This operating manual contains instructions for using the hand-operated sweeper.

Our products are subject to continuous improvement. Therefore, design changes that were made after this manual went to print could not be incorporated. If you have any questions, please contact our Service department.

The operating manual must be read and applied by all persons who operate the sweeper.

Apart from the operating manual and the regulations for accident prevention applicable in the country of use and the location of use, the common, recognised rules for safe and technically correct working must also be followed.

## 1.1 Usage conformant with intended purpose

The appliance is intended exclusively for sweeping on solid surfaces (for example.: parking areas, walkways, shop floors). The area to be swept should not be wet.

The sweeper may only be used by reliable and instructed personnel. prevent children, juveniles and other unauthorised persons from using the machine (e.g. by pulling out the key after use).

Any other use, or any use over and above that, will be considered to be non-conformant with intended purpose. The manufacturer rejects any and all liability for damage resulting from such use. The risk is that of the user alone.

Usage conformant with intended purpose also includes compliance with the operating manual and the inspection and maintenance specifications. Drive the sweeper only along expressly marked routes and spaces.

## 2 Safety information

---

1. The machine should only be used in a flawless state, as well as in keeping with its intended purpose, in a safety-conscious and risk-conscious manner and in compliance with these operating instructions.
2. In addition to the operating manual, please heed general legal and other binding regulations for accident prevention and environmental protection.
3. Sweeping and picking up of flammable, toxic or explosive substances, along with flammable gases or diluted acids and solvents, burning or smouldering objects is prohibited!
4. The appliance is not suitable for picking up fluids, cables, cords, wires or the like.
5. The machine should only be used with the dust box fitted to prevent injuries caused by parts being slung out.
6. Transporting loads with the sweeper is not allowed.
7. Faults should be eliminated immediately, particularly those that could impair safety.
8. Do not make any changes, modifications or additions to the sweeper without the approval of the manufacturer.
9. Replacement parts must meet manufacturer specifications. This is always ensured by using original replacement parts.
10. Ensure that operating media, auxiliary media and replacement parts are disposed of in a safe and environmentally-friendly manner, particularly batteries!
11. Suitable non-slip footwear should be worn to avoid accidents.
12. If you have any questions, please contact our Service department.
13. Persons (including children) who are not able to use this machine safely due to their physical, sensory or mental capabilities or their inexperience or lack of knowledge may not use this machine without the supervision or instruction by a responsible person! Children should be supervised to ensure that they do not play with the appliance.
14. Caution: loose clothing can be caught and drawn in on rotating parts.
15. The operating instructions provided by the battery manufacturer relating to his product and legal specifications for the handling of accumulator batteries should be heeded!

## Safety information

---

16. Charge flat batteries directly after use and only in well-ventilated rooms.
17. Keep naked flames and electrical sparks away from the charging area, since a highly-explosive electrolytic gas mixture is generated when batteries are being charged.
18. Note that the accumulator batteries are filled with battery acid.
19. Batteries should always be kept clean and dry to avoid leakage currents! Never short-circuit battery poles!
20. Smoking, eating and drinking should be avoided in the vicinity of the battery charging station to avoid risks to health.
21. Batteries should only be charged with the hood opened and secured with the holder.



### 3 Device Description

The Sweeping & Suction Machine is driven by electric motors. Model TT/E 900 operates by using a pivotable side brush to convey the sweepings to the two sweeping rollers arranged parallel to the direction of motion. These project the sweepings overhead into the dust container positioned behind it.

Optionally two side brushes may be installed. Model TT/E 1100 is equipped with two pivotable side brushes. If necessary, the dust stirred up by the sweeping rollers is caught by the dust suction unit in a lamellar filter inside the machine. The lamellar filter is cleaned by an electrically controlled filter cleaning device.

- |   |  |   |                                    |
|---|--|---|------------------------------------|
| 1 | battery condition display              | 2 | switch for the direction of motion |
| 3 | switch for sweeping rollers            | 4 | switch for side brushes            |
| 5 | switch for suction                     | 6 | switch for filter cleaning         |
| 7 | lowering lever for the sweeping roller | 8 | key switch                         |
| 9 | battery master switch (EMERGENCY OFF)  |   |                                    |

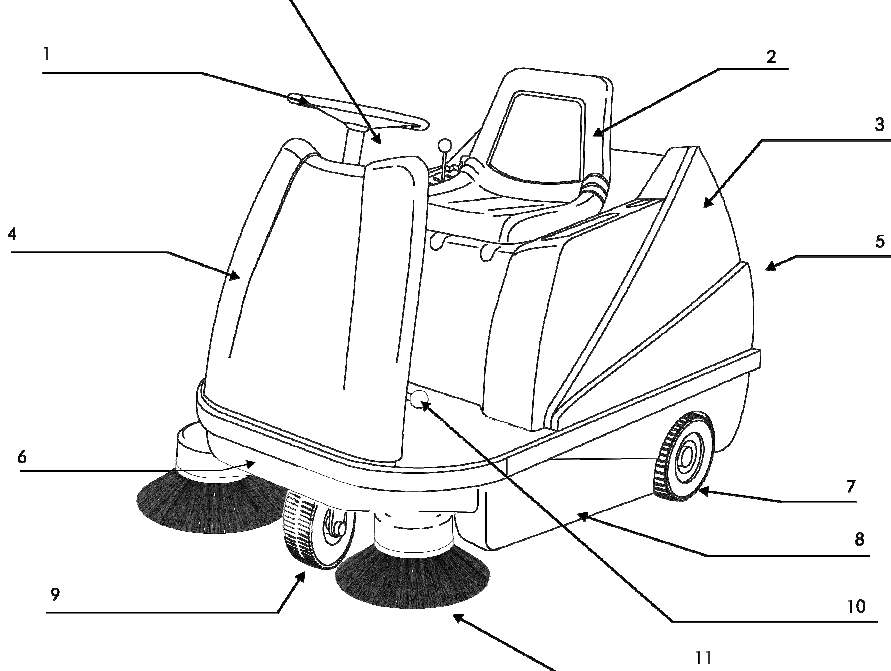
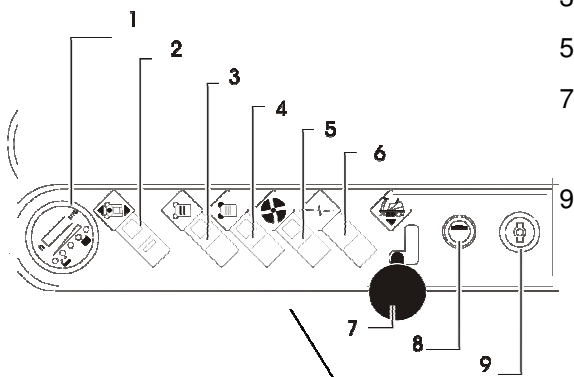

- |    |                                     |
|----|-------------------------------------|
| 1  | steering wheel with steering pillar |
| 2  | driver's seat                       |
| 3  | main trim panel                     |
| 4  | steering pillar trim                |
| 5  | dust container                      |
| 6  | front trim panel                    |
| 7  | driving wheel                       |
| 8  | left side trim panel                |
| 9  | rear wheel with drum break          |
| 10 | lowering lever for side brushes     |
| 11 | pivotable side brushes              |

### 3.1 Initial Startup

The Sweeping & Suction Machine standard delivery is without batteries or charging device.

Optional:

The Sweeping & Suction Machine is supplied with batteries

**Standard:**

- Open the transport packaging.
- Take off the complete hood. Lift up hood at back and lift the front spigots of the hood out of the retaining.
- Fit in the batteries.
- Connect the batteries. Compare technical data circuit diagram.
- Replace the hood panel.
- Mount the side brushes (cf. 5.11.2).
- The Sweeping & Suction Machine is ready for use.
- Drive the Sweeping & Suction Machine over a ramp out of the transport packaging.

---

Use a unit ramp. The ramp must be designed in such a way as to allow the rear wheel as well as the drive wheels to travel across it.

If this is not observed, damages to the Sweeping & Suction Machine mechanics will occur.

---

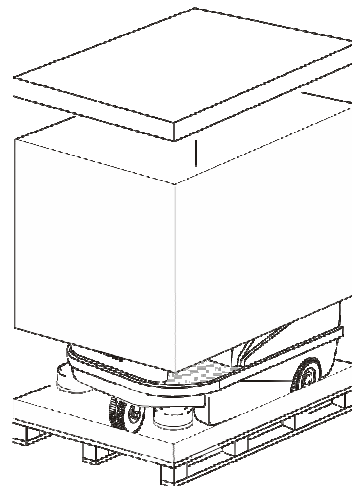

1 Elements of the Transport Packaging.

### Optional:

The Sweeping & Suction Machine is equipped with batteries.

- Open the transport packaging.
- Open the hood
- Lock hood securely using the hood arrester.

The hood is equipped with drill holes at the bottom

- Fit the hood arrester into the corresponding drill hole.
- Connect the positive pole of the battery.
- Close the hood.
- Mount the side brushes (cf. 5.11.2).

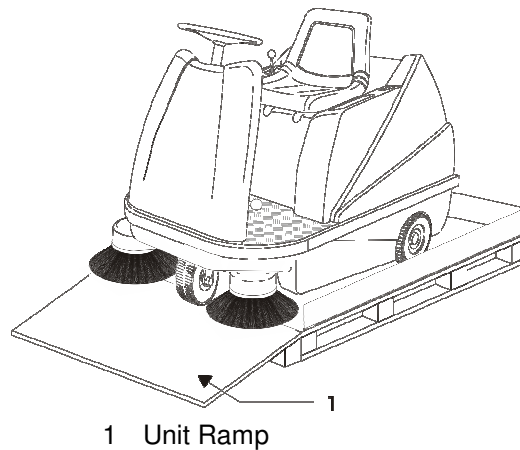

- Drive the Sweeping & Suction Machine over a ramp out of the transport packaging. (Cf. 4.1)

---

Use a unit ramp. The ramp must be designed in such a way as to allow the rear wheel as well as the drive wheels to travel across it.

If this is not observed, damages to the Sweeping & Suction Machine mechanics will occur.

---

The Sweeping & Suction Machine is ready for use.

## 4 Operation

### 4.1 Driving

- Starting the Sweeping & Suction Machine
- Sit down in the driver`s seat
- The Sweeping & Suction Machine cannot be started if the driver's seat is not weighed down.
- Check position of direction of motion switch.

The direction of motion switch is a toggle switch with two positions.

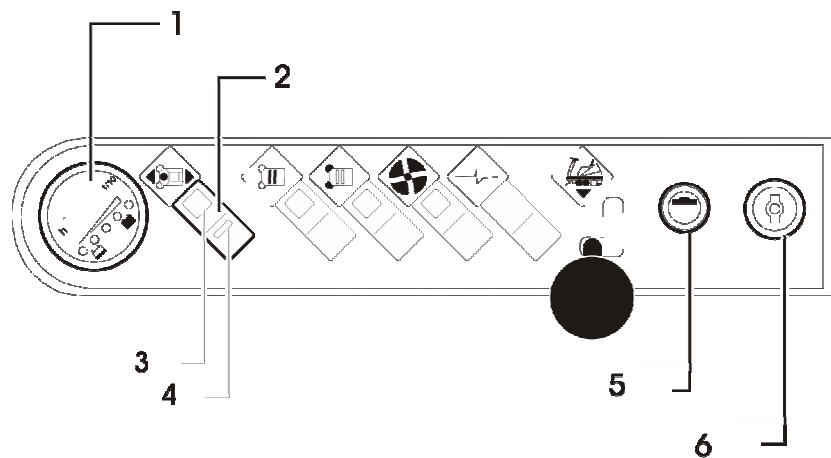

- |                              |                             |
|------------------------------|-----------------------------|
| 1 Control panel              | 2 Battery condition display |
| 3 direction of motion switch | 4 Pilot lamp forward motion |
| 5 Pilot lamp reverse motion  | 6 key switch                |
| 7 battery master switch      |                             |

- Insert the battery master switch into the socket.
- Press it down and turn it clockwise until it is firmly latched.
- Now pull up the battery master switch.
- Insert the key into the key switch.
- Turn the key clockwise.

On the control panel a red LED starts flashing. (This indicates machine ready for operation.) After that the LEDs indicating the battery's charging condition light up.

- Depress the brake pedal.
- Release the parking brake.
- Actuate the direction of motion switch.

**4.1.1 Forward motion:**

Push the direction of motion switch forward.  
Optical signal:  
Green pilot lamp on the switch

**4.1.2 Reverse motion:**

Push the direction of motion switch backward.  
Optical signal:  
Red pilot lamp on the switch,  
Acoustical signal: Beeper (optional)

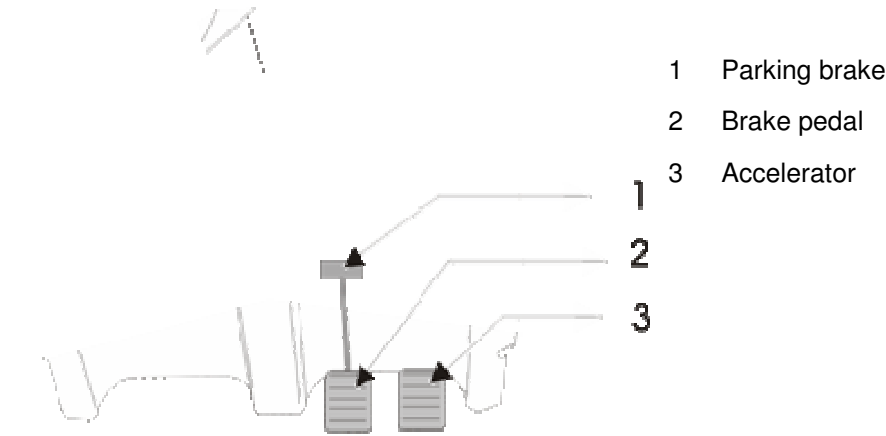

The speed of the Sweeping & Suction Machine can be adjusted with infinite variability by depressing the accelerator.

### 4.2 Sweeping

Do not switch on suction when sweepings are wet. This will cause damage to the suction device and the filter. Provide good aeration when using the machine in closed rooms or buildings.

Do not sweep up materials that may cause health impairment.

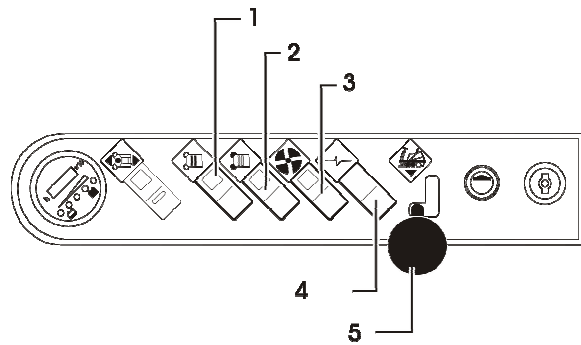

- |   |  |   |                                |
|---|--|---|--------------------------------|
| 1 | switch for the sweeping rollers        | 2 | switch for the side brushes    |
| 3 | switch for the suction                 | 4 | switch for the filter cleaning |
| 5 | lowering lever for the sweeping roller |   |                                |

#### 4.2.1 Sweeping Roller Drive

The sweeping roller drive is situated on the right side of the Sweeping & Suction Machine facing in driving direction.

The sweeping rollers are driven by an electric motor via a chain.

The chain is deflected by a sprocket and guided over the sprockets of the roller drive.

A spring biased chain tensioner keeps the chain tight.

Grease the sprockets at regular intervals. Cf. Maintenance Chart.

To grease the sprockets, open the hood and remove the side trim panel.

#### 4.2.2 Operatting the Sweeping Rollers

Start the Sweeping & Suction Machine

- Switch the toggle switch for the sweeping rollers to ON Position.
- Unlatch the lowering lever of the sweeping roller.
- The pilot lamp on the switch lights up.
- The sweeping rollers begin rotating.

Stopping Sweeping Rollers Operation

- Pull lowering lever of the sweeping rollers towards yourself
- Switch toggle switch for the sweeping rollers to OFF position
- Let the lever snap in arresting position

### 4.3 Operating the Side Brushes

The side brushes are fixed to swingers.

Whenever the side brushes hit an obstacle they swing back under the vehicle to avoid damages.

- Start the Sweeping & Suction Machine.
- Unlatch the lowering lever of the side brushes.
- Switch toggle switch for the side brushes to ON position.
- Push the lever down.

The pilot lamp on the switch lights up.

The side brushes begin to rotate.

Stopping Side Brush Operating.

- Switch toggle switch for the side brushes to OFF position.
- Pull up the lowering lever for the side brushes. Let the lever snap in arresting position

### 4.4 Information provided by LED indicators on the battery condition display:

lit LED	charging condition	battery
Red Yellow Green Green Green		
		condition fully charged
		operating/charging condition uncritical
		operating/only for a short time longer
		operating/soon critical
		operating/critical

### 4.5 Operating the Suction

The suction prevents dust formation during sweeping operations.

- Start the Sweeping & Suction Machine.
- Switch the toggle switch for the suction to ON position.
- The pilot lamp on the switch lights up.
- The suction begins operating.

To turn off suction operation switch the toggle switch for the suction to OFF position.



---

**Please observe!**

**Do not switch on suction when sweepings are wet.**

**This will cause damage to the suction device.!**

---

To turn off suction operation switch the toggle switch for the suction to OFF position.

### **4.6 Adjustment of Driver`s Seat**

- Loosen the seat arresting device and shift the driver's seat on the seat support to a position that feels comfortable to you.

### **4.7 Turning Off the Sweeping & Suction Machine**

- Depress the brake pedal.
- Lock the brake by pulling the locking lever towards the driver's seat.

When the brake now is relieved the brake pedal must remain in depressed position.

All of the pilot lamps on the switch are off.

- Switch off all actuators.
- Lift up the side brushes and arrest the lowering lever for the side brushes.
- Lift up the sweeping rollers and arrest the lowering lever for the sweeping rollers.
- Turn the key counterclockwise and remove it from the key switch.
- Turn the battery master switch counterclockwise and remove it from the socket.

### **4.8 Operating the Filter Cleaning Device**

The filter cleaning device prevents the lamellar filter from being blocked by debris.

- Switch off suction.
- Wait until ventilation wheel stands still.
- Apply filter cleaning device at regular intervals.
- Depress the toggle switch for the filter cleaning device for about 5 to 10 seconds.

The filter cleaning device begins operation.



## 4.9 Emptying the Dust Container

The dust container is the place where the sweepings are collected.

It is positioned at the back of the Sweeping & Suction Machine.

The dust container must be emptied regularly and especially after each use.

### 4.9.1 Removing the Dust Container

Turn the dust container locking upward.

Pull out the dust container from the Sweeping – & Suction Machine by the gripping handle until the front dust container guide rails are free.

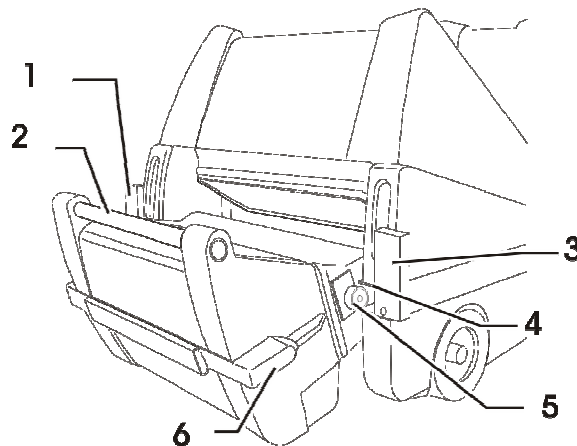

- |                         |                 |
|-------------------------|-----------------|
| 1 locking device        | 2 recessed grip |
| 3 locking device        | 4 guide rail    |
| 5 dust container guides | 6 roller        |

At the back of the dust container two guiding rollers are installed to make the removal easier.

- Lower the dust container to the ground

A number of rollers and a recessed grip are positioned at the bottom of the dust container.

- Remove the dust container completely from the Sweeping & Suction Machine.
- In order to empty the dust collecting box use the free hand to take hold of the recessed grip.
- The sweepings are discharged through the opening at the bottom of the dust bin.
- Empty sweepings into appropriate containers only.

### 4.9.2 Reinserting the Dust Container

- Place the dust container before the dust container retaining.
- Bring the dust container's front guides up to the same level as the guide rails.
- Slide the dust container into the Sweeping & Suction Machine.
- Turn the locking device downward.

---

## 5 Maintenance

### 5.1 Safety Information

Only complete the type of maintenance work described in the following chapter. All other maintenance and upkeep work may only be carried out by the manufacturer or by companies and persons authorised by the manufacturer, who are familiar with the relevant safety specifications, because portable devices in industrial use are subject to the safety test according to VDE 0701.

Closely follow the steps listed in the maintenance instructions. The improper completion of maintenance tasks may result in malfunctions when using the sweeper and may possibly render the warranty granted null and void.

When working on the electrical system, the battery should be disconnected.

Maintenance work/ troubleshooting at the electric motor must not be done while the electric motor is running.

Use only flawless and appropriate tools to complete maintenance work.

Note the requirements for spare parts (see Spare parts).

If covers and/or safety devices were removed during maintenance work/repairs, they will have to be reattached prior to starting the sweeper.

For carrying out any work on the sweeper, it must be switched off and secured from rolling away by accident.

### 5.2 Cleaning

The suction sweeper may only be cleaned in the off state, when it is dry.

The suction sweeper is a machine with electrical components.

**WARNING**



---

**Moisture damages the electronics of the device. Moisture can result in leakage currents and short-circuits.!**

---

**Do not use any high-pressure cleaners**

### 5.3 Charging the Batteries

- Turn off the Sweeping & Suction Machine.
- Open the hood.
- Secure the hood position by the hood arresting device.
- Guide the hood arresting into the holes at the bottom of the hood.
- Connect the charging device to the charging plug of the Sweeping & Suction Machine.
- Connect the mains plug of the charging device to a power supply socket.

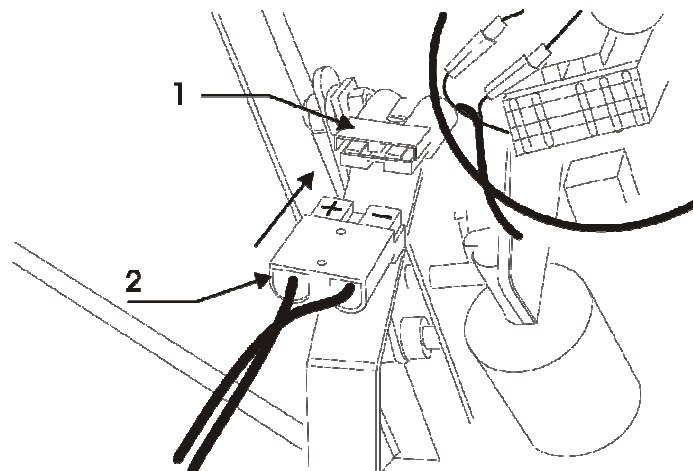

1 charging socket of Sweeping & Suction Machine

2 charging plug of charging device

The charging process lasts for approx. 10 hours when the batteries have been completely used up (with the device originally provided by the manufacturer).

The original charging device of the manufacturer can/should remain connected after charging is completed, because it is equipped with a charge saver allowing it to provide highest possible battery capacities even after long periods of standstill.

Be careful only to use the Sweeping & Suction Machine if there is enough voltage left in the batteries.

The machine automatically switches itself off, if the batteries are discharged to such a degree that damages may arise (exhaustive discharge protection)

In this case: Switch off all consumers and let the machine stand for about one or two minutes.

Switch on the machine again and drive to the charging device (without sweeping operation!) Charge batteries immediately to avoid possible damages.

## 5.4 Battery

Four batteries supply the Sweeping & Suction Machine with electrical power. The charging condition of the batteries is indicated by the battery condition display on the control panel.

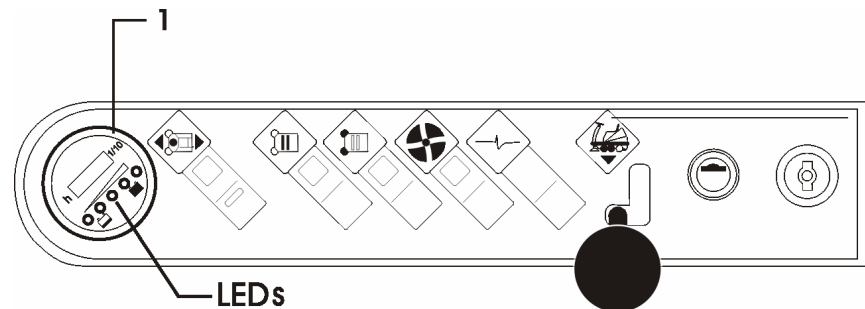

1 Batteriezustands-Armatur

When the Sweeping & Suction Machine is switched on the red LED flashes five times.

Subsequently the electronic system of the Sweeping & Suction Machine carries out a self-testing operation of the battery charging state.

The result of this self-testing is displayed by the 5 LEDs.

## 5.5 Brake

**DANGER!**



**The brake is a component affecting operational safety. All work pertaining to the maintenance and replacement of brake parts must be executed by professionally trained personnel!**

The brake (drum brake) acts on the rear wheel and is controlled via Bowden pull wire by the brake pedal.

The brake adjustment is situated on the right side of the rear wheel facing in driving direction.

### 5.5.1 Adjusting the Brake

- Hold the adjustment nut of the Bowden pull wire in place with a wrench.
- Loosen the back nut of the Bowden pull wire.
- Push the brake lever upward until the brake lever is obstructed.
- Hold the brake lever in this position.
- Tighten the back nut of the Bowden pull wire.

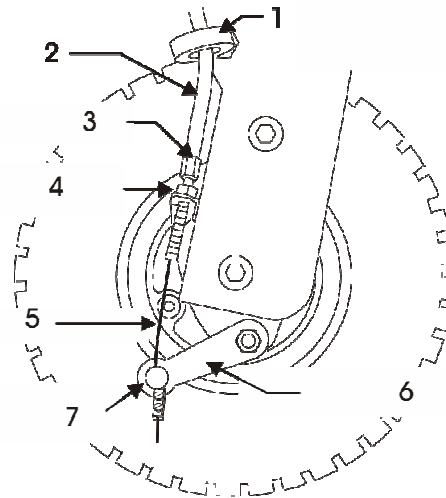

- |                            |                    |
|----------------------------|--------------------|
| 1 Bowden pull wire guiding | 2 Bowden pull wire |
| 3 adjustment nut           | 4 back nut         |
| 5 brake pulley             | 6 brake lever      |
| 7 brake pulley arresting   |                    |

Now conduct a brake check.

## 5.6 Brake Check

### Free Movement of Rear Wheel

You must be able to move the Sweeping & Suction Machine by pushing when the brake is released.

The rear wheel must not be blocked. Brakes that are set too tightly damage the brake drum.

### 5.6.1 Correct Operating of Brake

Carefully drive a few meters at moderate speed.

Depress the brake pedal. The Sweeping & Suction Machine must stop.

If the brake check should not render a satisfying result the setting procedure must be repeated.

#### Further Setting Possibility:

The Bowden pull wire does not allow tightening in the way described above any longer.

- Loosen the brake pulley arresting.
- Lift the brake lever up until it is obstructed.
- Hold the brake lever in this position.
- Pull the brake pulley down and push the brake pulley arresting upward.
- Fasten the brake pulley arresting.

- Carry out the above described brake check.

## 5.7 Steering

The steering transferral to the rear wheel is managed by a chain and two chain sprockets.

Grease the chain sprockets at regular intervals. Cf. Maintenance Chart.

## 5.8 Replacement of Filter

The filter removes fine dust.

The filter is cleaned by an electrical vibrating device.

### 5.8.1 Removal

- Open the hood.
- Lock hood securely using the hood arrester.

The filter is held in the fixture by 4 star handles.

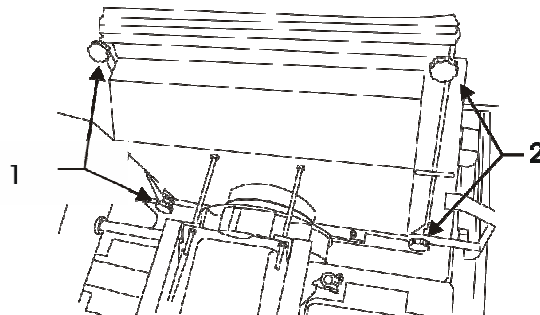

1 star handle

2 star handle

- Loosen the top two star handles.
- Swing up the top angular bracket.
- Loosen the bottom two star handles.
- Pull the filter out of the fixture.

### 5.8.2 Reinsertion

- Place the filter into the lower angular bracket.
- Swing the upper bracket over the filter..
- Tighten the top star handles slightly.
- Tighten star handles evenly crosswise so that the filter snugly fits all around the seal.
- Adjust the bolts and the nuts in a way that, provides the filter with the best possible sealing inside the casing.

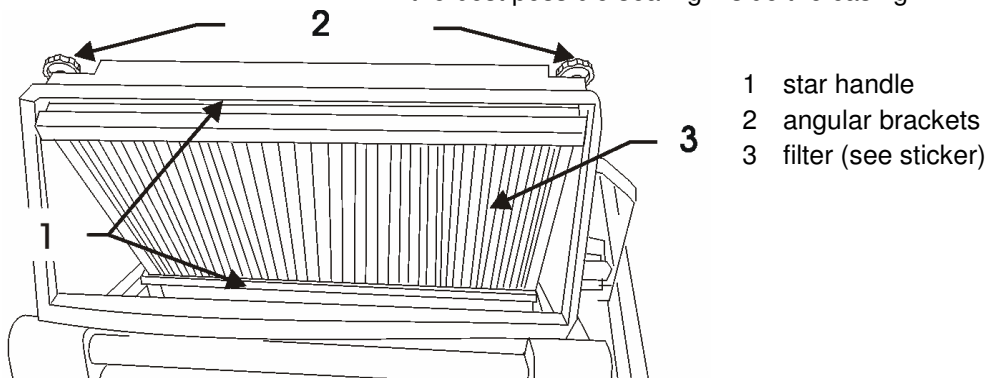

## 5.9 Sweeping Rollers Replacement

### 5.9.1 Dismounting the Sweeping Rollers

- Turn off the Sweeping & Suction Machine.
- Switch off the EMERGENCY OFF to avoid accidental starting.
- Pull lowering lever of the sweeping rollers.
- Arrest the lowering lever.
- Loosen the bolts of the left side trim panel facing in driving direction.

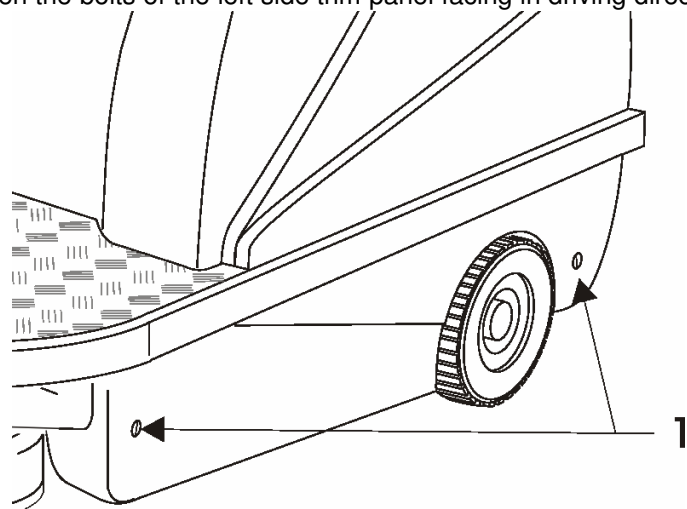

1 fastening bolts of side trim panel



- Remove the side panel.

The roller swing is held in place by three star handles.

- Loosen the star handles.
- Remove the roller swing.

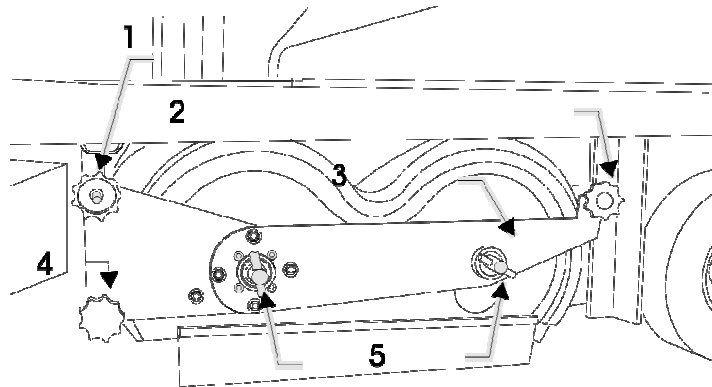

- |                    |                            |
|--------------------|----------------------------|
| 1 open star handle | 2 star handle with marking |
| 3 roller swing     | 4 star handle              |
| 5 turning lever    |                            |

- Pull the sweeping rollers out of the machine and remove any debris, cords, etc., from the roller tunnel and from the pick-up pins.

### 5.9.2 Installing the Sweeping Rollers

- Push the sweeping rollers under the machine.

Observe the sweeping rollers' sense of rotation while sliding them in.

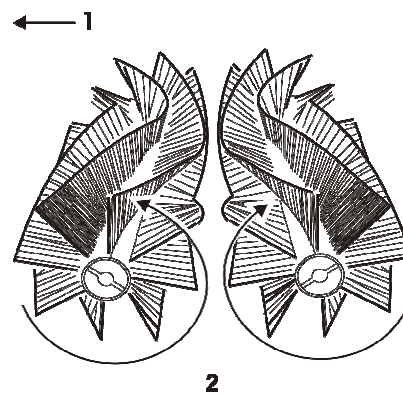

- |                 |   |
|-----------------|---|
| 1 forward drive | 2 direction of motion of the sweeping rollers |
|-----------------|---|

Each roller end is equipped with a keyway.

Turn the sweeping roller until the pick-up pin of the rear roller swing fits into the keyway of the sweeping roller.

Slide the sweeping rollers in as far as possible.

Set the front roller swing onto the free sweeping roller ends.

The roller swing is equipped with two turning levers.

Each turning lever end is equipped with one pick-up pin.

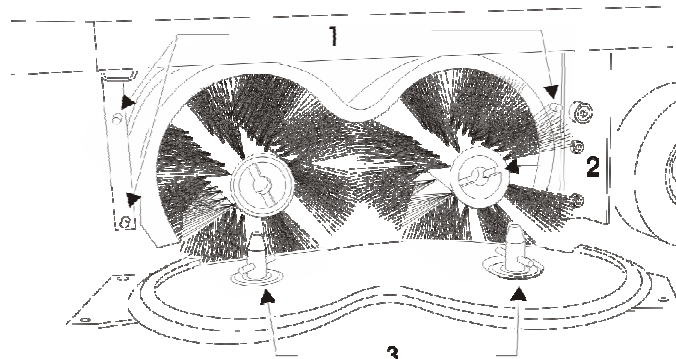

- 1 threaded rods  
2 sweeping roller keyway  
3 pick-up pin

- Turn the turning lever until the pick-up pin fits into the keyway of the sweeping rollers.
- Push the roller swing over the threaded rods.
- Make sure the sweeping rollers are fitted on both sides by the keyway into the pick-up pins and that all star handles are firmly tightened.
- Fasten the side trim panel.

## 5.10 Setting the Sweeping Rollers

### 5.10.1 Sweeping Contour Adjustment

For best cleaning results and to ensure the highest possible device efficiency, the sweeping rollers are equipped with a sweeping contour.

The sweeping contour should be set to approx. 50-60 mm at the rear roller.

#### **Establishing the Sweeping Contour:**

Drive the Sweeping & Suction Machine to an area to be cleaned. Switch on the sweeping rollers without moving the sweeping machine. Allow the sweeping rollers to run for about one or two minutes without moving. Lift the sweeping rollers. Stop sweeping rollers operation and drive forward a few meters. The sweeping track visible on the ground is the sweeping contour.

### 5.10.2 Adjusting the Sweeping Contour

- Switch off the Sweeping & Suction Machine.
- Pull lowering lever of the sweeping rollers.
- Arrest the lowering lever.
- Open the hood.
- Secure the hood position by the hood arresting device.
- Guide the hood arresting into the holes at the bottom of the hood.
- Remove the right side trim panel facing in the direction of motion.

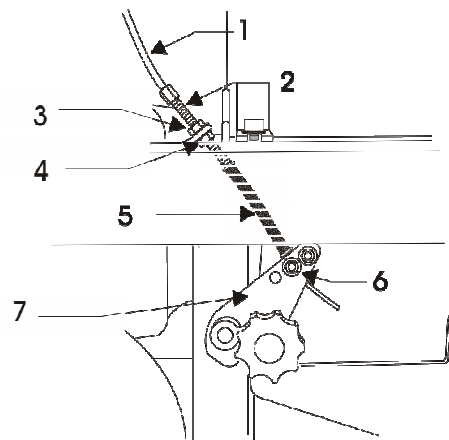

- |   |                           |   |               |
|---|---------------------------|---|---------------|
| 1 | Bowden pull wire          | 2 | threading rod |
| 3 | counternut A              | 4 | counternut B  |
| 5 | spring                    | 6 | holding screw |
| 7 | sweeping roller retaining |   |               |

#### Increasing the Sweeping Contour by Lowering Sweeping Rollers

- Loosen counternut A on the threading rod of the Bowden pull wire.
- Turn counternut A counterclockwise.
- Now lock counternut A in place by counternut B

#### Decreasing Sweeping Contour by Lifting Sweeping Rollers

- Loosen counternut B
- Turn counternut B clockwise by a few more threads.
- Lock counternut B in position by counternut A.

### 5.10.3 Further Possible Adjustment:

Take off side trim panel to the right facing in direction of motion.

- Loosen the holding screw.
- Move sweeping roller retaining to desired position.
- Tighten up the holding screw again and mount the side trim panel.

Original roller diameter: 285 mm.

When diameter has decreased to 245 mm, the roller needs to be replaced.

---

## 5.11 Replacing the Side Brush

### 5.11.1 Dismounting the Side Brush

- Turn off the Sweeping & Suction Machine.
- Pull up the lowering lever for the side brushes.
- Arrest the lowering lever.
- Lift up the side brush motor in order to get easy access to the fastening screws at the lower center of the side brush.

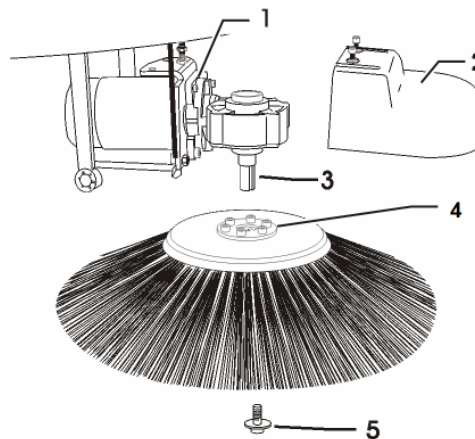

- |                     |                            |
|---------------------|----------------------------|
| 1 side brush motor  | 2 side brush trimming      |
| 3 shaft with keyway | 4 flange base with locking |
| 5 fastening screw   |                            |

- Loosen the fastening screw at bottom center of each side brush.
- Pull the side brush down and off.
- Replace the side brush.

### 5.11.2 Mounting the Side Brush

- Fasten the flange plate to the side brush.

The flange plate is equipped with a locking.

The side brush motor shaft is equipped with a keyway.

- Turn the side brush until the feather key fits snugly into the keyway.
- Fasten the side brush to the shaft of the side brush motor by us of the fastening screw.

## 5.12 Adjustment of the Side Brush

Operational wear necessitates additional adjustment of the side brushes.

- Turn off the Sweeping & Suction Machine.
- Unlatch the lowering lever of the side brushes.
- Push down the lowering lever.
- Loosen the bolts of the front panel.
- Remove the front panel.

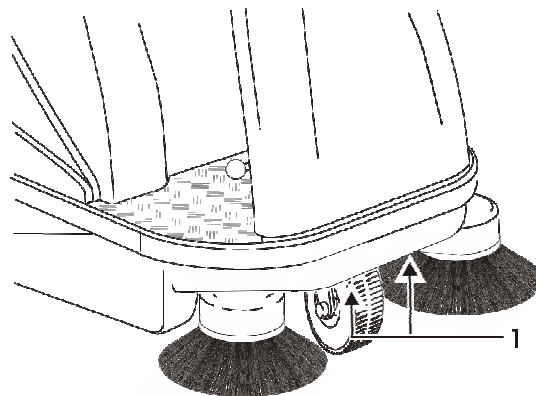

1 bolts for the front panel

- Loosen the bolt of the side brush level adjustment.
- Move the side brush to the desired position. .
- Tighten the bolt of the side brush level adjustment.

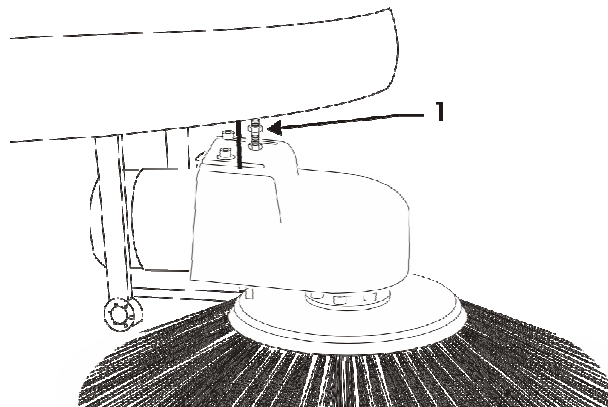

1 level adjustment bolt for side brush

- Fasten the front panel.

### 5.13 Wheels

The Sweeping & Suction Machine is equipped with three wheels. The standard rear wheel tire is made of solid rubber. The two drive wheels are standard equipped with pneumatic tires. Optionally the drive wheels are delivered with solid rubber tires. Defective tires must be repaired or replaced by expert shops only. Deliver the complete wheel (rim and tire) to the tire shop.

### 5.14 Fuses

The Fuse box is positioned on the right side under the hood, facing in driving direction.

The fuses are arranged in the same order as the instruments on the control panel.

- Do not repair fuses
- Do not replace fuses by stronger fuses.
- This will damage the system
- It may lead to a short-circuit and possibly to a fire.

### 5.15 Maintenance Chart

#### 5.15.1 Daily maintenance

- Check battery acid level, if required replenish distilled water.
- Charge battery.
- Check if machine is damaged or impaired in any way.
- Check condition of dust filter and clean if necessary.
- Empty dust container.

#### 5.15.2 After each 50 operating hours also

- Check if battery leaks acid.
- Clean and grease battery poles.
- Check if sweeping rollers are worn or cluttered. Replace if required.
- Check sweeping contour, readjust if required.
- Check if side brush adjustment is worn, if required readjust or replace.

- Search brush - roller tunnel for jammed particles and seized up dirt that may narrow the brush tunnel and obstruct free roller brush movement.

### **5.15.3 After each 100 operating hours also**

- Check cable isolation, replace cables if required.
- Check if cable connections are tight.
- Grease steering chain.
- Greas sweeping roller drive chain.
- Clean dust filter, replace if necessary.
- Search suction for obstacles, clean.
- Conduct trial run to check all operating elements.
- Check if roller drive chain is elongated or loosened.
- Check all bearings for wear.
- Check if seals are damaged or dislocated.

### **5.15.4 After each 200 operating hours also**

- Check operation of electric motors.
- Check if carbon brushes are worn, replace if required.
- Check steering clearance, tighten chain if required.
- Check all electrical system components whether they are soiled.

## 5.16 Disturbances, Disturbance Display, Remedy

Disturbance	Possible Cause	Remedy
No operating display at control panel:	EMERGENCY OFF not switched on Key switch not switched on Seat contactor or hood contactor not actuated Fault in electrical wiring Battery empty	Turn EMERGENCY OFF switch into socket Turn key switch and check correct load Check plug connections Charge battery
No operation of propelling drive in spite of display at control panel:	Direction of motion switch was set to forward or reverse motion during start Accelerator was depressed at start Fuse 1 defective Fault in electrical connections Problems in electronic control	Switch to neutral and then again to desired neutral position Release accelerator Replace fuse Check plug connections and compare indication by red LED at control panel
No operation of one of the electrical consumers:	Fuse defective Fault in electric connections Fuses permanently defective	Replace fuse Check plug connections of corresponding system component: check especially sweeping rollers whether obstructed by bands, cables, strings
Sweeping result unsatisfactory:	Side brush(es) or main sweeping rollers not lowered Side brush(es) or main sweeping rollers worn Trajectory clogged by dirt Sweeping roller(s) do not operate Dust formation too great Suction turbine does not operate Filter heavily polluted Filter not correctly fitted Leakage and subsequent aspiration of false air in the filter chamber	Lower Adjust Check if roller trim panel is impaired by jammed debris Correctly fitted? Does motor revolve? if required switch off side brushes Check is electrically defective Clean filter check for tight fit check if false air is sucked in
Fuses of the sweeping roller do not remain set	Brush rollers are jammed by dirt, cords, strings or the like	Dismount brush rollers and clean them
Fuses of the side brushes do not remain set	Side brushes are jammed by dirt, cords, strings or the like	Check side brushes and remove obstacles



Disturbance	Possible Cause	Remedy
Fuse of ator does not remain set	Ator does not move freely	Check ventilator wheel and remove any obstruction
Fuse of propelling drive does not remain set	Drive wheels obstructed	Jack up the Sweeping & Suction Machine check differential operation of wheels and free running

## 5.17 Technical Data

Dimension and Weight	
Length:	approx. 1.450 mm
Width:	900 mm
Height:	approx. 1165 mm upper edge of steering wheel
Weight:	
without batteries	201 Kg
with batteries	331 Kg
Sweeping Width	
without side brush	700 mm
with one side brush	900 mm
with two side brushes	1.100 mm
Dust Container Volume	90 Ltrs.
Climbing Capacity	20%
Speed	0-6 km/h
Filter Area	4 m <sup>2</sup>
Air Volume of the	900 m <sup>3</sup>
Dust Suction	
supporting frame	Steel construction, powder coated
Trim Panel Parts	impact resistant plastic

Electrical Installation	
Power supply: 4 batteries with je 6V 180 Ah (5h) each. Running time of battery version:	>4 h
Fuses:	
Vibrator:	24 V 10A
Ventilator:	24 V 30A

<b>Electrical Installation</b>	
Side brushes:	24 V 20A
Sweeping rollers:	24 V 40A
Driving switch:	24 V 45A

<b>Maximum Airborne Sound Level: 71 dB (A)</b>	
Weighted Effective Acceleration Value upper extremities are subjected to	<2,5m/s <sup>2</sup>

<b>Tires</b>	
Front: 1 solid rubber tire	
Back : 2 pneumatic tires	
Optional: 2 solid rubber tires	
	Tire size: 260 x 85
	Air pressure: 5,5 bar

<b>Brake</b>	
Drum brake	Acting on front wheel
Parking brake	

## 5.18 Product Marking



## 5.19 Disposal

Dispose of faulty parts, especially electrical components, batteries and plastic parts according to the locally applicable waste disposal specifications.

Used batteries must be disposed of according to Directive 2006/66/EC.

## 5.20 Accessories and spare parts

Accessories and spare parts must conform to the requirements of the manufacturer. This is ensured by using genuine replacement parts.

## 5.21 Service

Stolzenberg GmbH & Co. KG

Hamburger Straße 15-17

D-49124 Georgsmarienhütte

Telefon: 0049 / (0)5401 83 53-0

Fax: 0049 / (0)5401 83 53-11

[www.Stolzenberg.de](http://www.Stolzenberg.de)

## 5.22 Transport

Transport the machine only in the switched-off condition, sufficiently well fastened.

## 5.23 Wiring Diagram

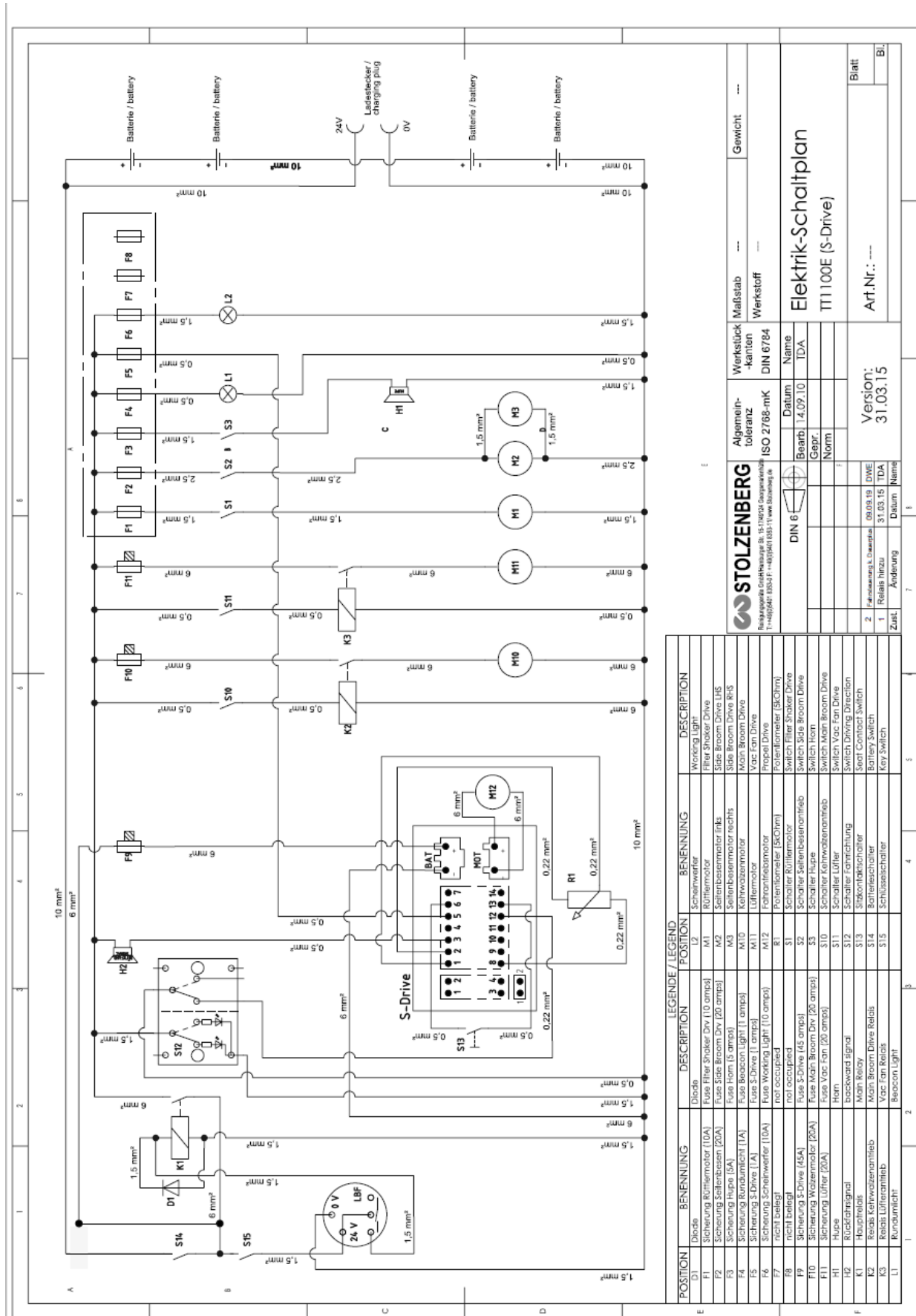

## 6 EC Declaration of conformity (Translation of the original version)

**according to the EC Machine Directive 2006/42/EC, Appendix II, No. 1A**

Mr. Kai Stolzenberg – Management of the Stolzenberg GmbH & Co. KG, Hamburger Straße 15-17, D-49124 Georgsmarienhütte - is authorized to arrange technical information.

**We hereby declare that the machine described below corresponds, in its conception and construction, as well as the model brought into use by us, to the basic safety and health requirements of the EC Machine Directive 2006/42/EC. In case of a change being made that has not previously been agreed with us, this declaration will lose its validity.**

Manufacturer:	Stolzenberg GmbH & Co. KG, Hamburger Straße 15-17, D-49124 Georgsmarienhütte
Designation of the machine:	TTE 1100
Machine type:	Suction sweeper with tandem-roller-system
relevant EC Directives:	Directive 2006/42/EC Directive 2000/14/EC Directive 2004/108/EC

**The following standards, in particular, were applied:**

EN 292  
EN 294

DIN EN 61000-6-2  
DIN EN 60335-1  
DIN EN 60335-2-69  
DIN EN 60335-2-72

Georgsmarienhütte, 26.01.2010

  
.....  
**Kai Stolzenberg**  
(Dipl. Wirtsch. Ing., Management)